

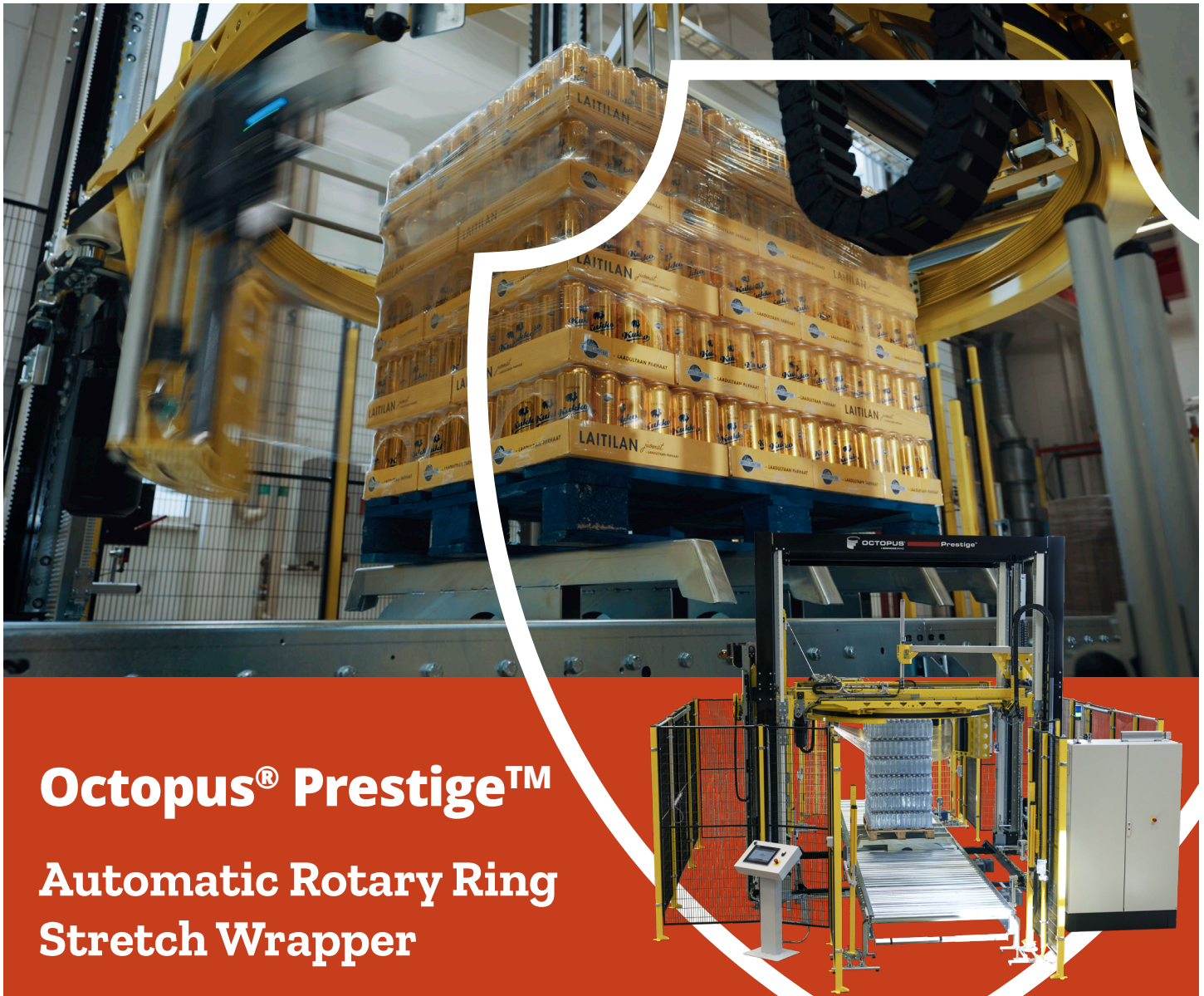

OCTOPUS[®]
A **SIGNODE** BRAND



Octopus[®] Prestige[™]

Automatic Rotary Ring Stretch Wrapper

Unmatched Throughput Performance

Consistent high output performance without compromising load stability

Built to endure. Designed to perform

Low maintenance design for long term reliability in demanding environments

Maintenance made effortless

TopDown Service and Maintenance. All service points accessible at floor level for reduced service time and improved safety

Intelligent Film Conversion

Delivers consistent load containment with reduced film consumption through intelligent pre-stretch technology



Octopus® Prestige™

Automatic Rotary Ring Stretch Wrapper



The Octopus Prestige stretch wrapper is a fully automatic pallet wrapping system designed for high-volume operations that demand speed, reliability, and consistency. Built on the proven rotary ring concept, it introduces two major innovations:

- **Intelligent Film Conversion Technology:** This system transforms standard stretch film into a highly efficient containment solution. By precisely controlling pre-stretch and film tension throughout the wrap cycle, it supports optimal film usage, consistent load stability, and reduced material waste.
- **Advanced Motion Control:** Instead of relying on multiple sensors and mechanical adjustments, the Octopus Prestige stretch wrapper uses smart motion algorithms to manage the wrapping process. This results in smoother operation, fewer wearing parts, and higher uptime—even at high speed.

Together, these technologies deliver a simplified yet powerful wrapping process that's easy to maintain and built to last.

Features and benefits

- **Reduced film consumption and improved load stability** enabled by the innovative Double-S film carriage, which optimizes film pre-stretching for consistent containment.
- **Lower maintenance costs and fewer spare parts** due to motion-controlled wrapping that results in a smooth, high-speed process with minimal sensor adjustments.
- **Faster and easier maintenance with less downtime** with **TopDown floor-level** service access, making all service points easily accessible at floor level.
- **Extended machine lifespan** and reliable high-speed performance supported by a robust ring rotation and hoist system designed for durability.
- **Faster top sheet film reel changes and reduced downtime** made possible by the integrated top sheet dispenser and top reel lifting system - all with economic access at floor level.

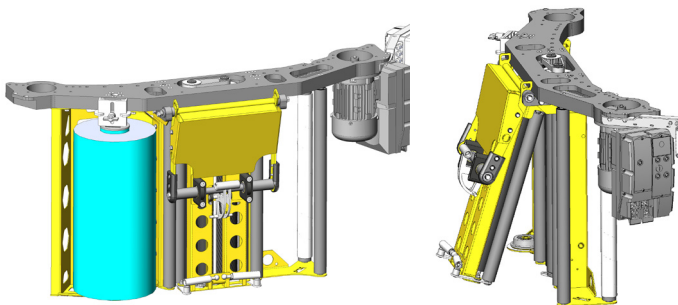

Double-S film carriage with easy load film roll change

Additional Standard Features

- **Navigator™ HMI** - Simplicity at your fingertips. The new Navigator human-machine interface redefines ease of use. With a clean, intuitive layout and guided workflows, even first-time users can confidently operate the machine. Real-time diagnostics, visual alerts, and customizable settings make Navigator HMI a powerful tool for both operators and technicians—helps minimizing training time and maximizing productivity.
- **Easy load film roll change** in the Double-S film carriage. The film distributor gate opens from the bottom edge via a handle and the film path forms a straight line through the pre-stretch system - no need to pull the film around any rollers.

Options

- **Film roping for improved load stability.** The increased holding forces in a roped film allow for possible down-gauging of film thickness and a reduction of film costs per pallet, without compromising on load stability.
- **Corner post device** that will place corner posts at each load corner for improved product protection and load stability.
- **Load stabilizer** to help unstable loads remain intact throughout the wrapping cycle.
- **RollCycler™ the next-generation film roll change system**, capable of holding up to 8 film rolls. Automatically switches rolls without manual intervention, reducing downtime and increasing efficiency.

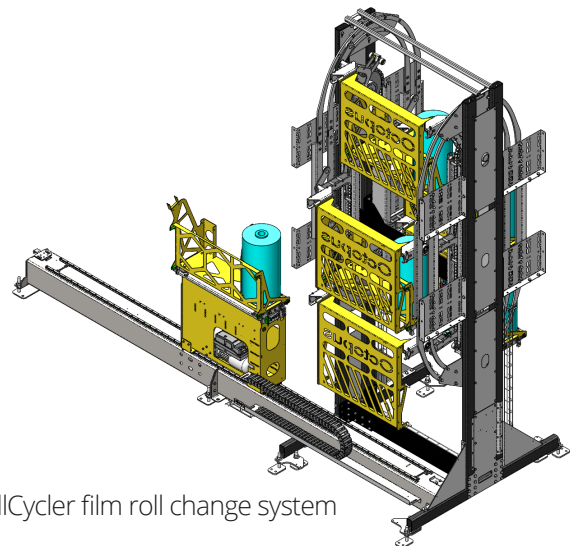

RollCycler film roll change system

